



**COGNEX**  
ID PRODUCTS



**DataMan**  
**7500 Series**  
**HANDHELD ID READERS**



## **RUGGED, ALL-IN-ONE DESIGN**

- IDMax decoder assures the highest reading yield on DPM codes
- UltraLight illumination system creates readable images from all marks
- Autodiscriminates reading of 1D and 2D codes
- Available in corded and cordless models
- Rugged, ergonomic design

# SETTING THE STANDARD

**DataMan™ 7500 Series handheld readers set the industry standard for reading Direct Part Mark (DPM) codes for part traceability.**

## Performance Plus Ruggedness

DPM identification for part traceability demands rugged, self-contained readers that perform consistently on all types of marks and parts. The DataMan 7500 Series offers the only readers in industry that read everything from the most challenging DPM marks to the easiest printed barcodes. And, these readers are designed to hold up to the harshest environments . . . up to 50 drops to concrete from two meters. When you add outstanding ergonomics to the list of breakthrough features, these readers are the clear choice for the factory floor.

## Corded and Cordless Versatility

The DataMan 7500 Series includes the 7500 corded and 7550 cordless models. Both models include the patent-pending UltraLight illumination technology and award-winning IDMax code reading software.

The DataMan 7500 supports USB, keyboard wedge, and RS-232 communications; the 7550 model uses Bluetooth communications to connect to the DataMan intelligent base station. Both readers offer a high-resolution image sensor and simple setup interface.

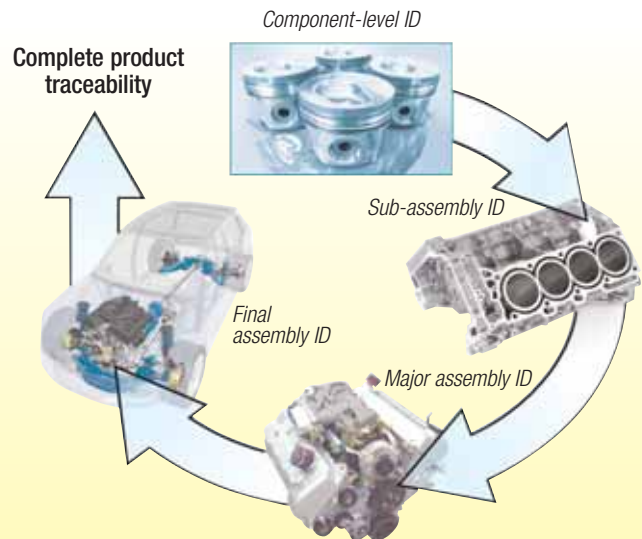

*DPM code identification at every step of a part's assembly assures traceability throughout its life.*



*The DataMan corded model 7500, and the cordless 7550 (shown in its intelligent base station), provide rugged and reliable DPM code reading for all applications.*

# DataMan

# DPM ID REQUIRES INNOVATION

Advanced code reading software and innovative illumination allow reading codes, regardless of marking method, part material, shape, or surface texture.

## IDMax Reading Software

DataMan readers incorporate IDMax™, a breakthrough in Data Matrix reading software based upon Cognex patented PatMax® technology. IDMax handles a wide range of degradations to the appearance of the code, no matter what the cause, allowing DataMan readers to deliver the industry's most reliable reading within a compact, easy-to-use handheld reader.

### Outstanding Performance with Problem 2D Codes

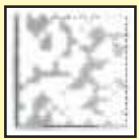

Poor Focus



Model Image



Washed Out

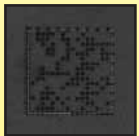

Low Contrast

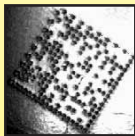

Finder Degradation



Background Problems

## UltraLight Illumination

The UltraLight™ illumination system allows DataMan readers to optimally illuminate marks of any type on any surface. Low-angle lighting with quadrant control provides the uniform illumination required for dot peen and laser etch marks. The integrated diffuser provides soft illumination required for highly reflective parts such as electrochemical etched marks on shiny round surfaces. Diffuse bright field illumination provides uniform lighting throughout a wide working range, which is ideal for 1D barcode labels and marks located on recessed surfaces.

### UltraLight Illumination System

The diagram illustrates the UltraLight Illumination System, which is a handheld reader with a central lens and four adjustable light sources (two red and two blue). The system is shown in various configurations to demonstrate its capabilities:

- Dark field illumination for dot peen and laser DPM:** Shows a dark background with a bright, high-contrast mark.
- Diffuse off-axis illumination for curved surfaces and highly-reflective surfaces:** Shows a light source positioned at an angle to illuminate a curved surface.
- Quadrant control for machined surfaces:** Shows the light sources positioned to illuminate a specific quadrant of a surface.
- Diffuse bright field illumination for labels and marks having good contrast:** Shows a bright, uniform light source illuminating a mark.

All light settings are software controlled.

# RELIABLE CODE READING FOR MANY INDUSTRIES

This high degree of reliability ensures the economic return required by part traceability objectives.



## Automotive Parts

Automotive suppliers use the DataMan 7500 Series throughout the manufacturing process for error proofing and traceability.



## Aerospace

Data Matrix codes have been adopted by the Aerospace industry to identify and track parts through production, as well as through the life of the parts.



## DoD

The DataMan 7500 Series supports the DoD and its supply base with Unique Identification (UID) reading.

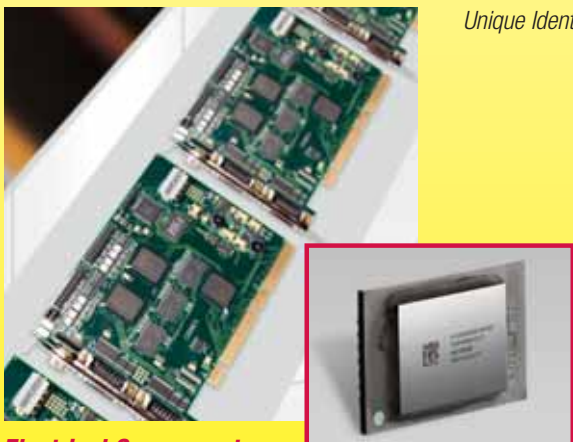

## Electrical Components

Electronics manufacturers moving from bar code labels to Data Matrix due to space constraints and the need to include more data on parts use DataMan readers to identify boards and components.



## Medical Equipment and Devices

Data Matrix codes support the initiative of Unique Identification Marks (UIM) on medical devices.

# SPECIFICATIONS

## ID Tools

2D	Data Matrix, QR Code
Bar code	EAN13, UPC-A, EAN8, UPC-E, Interleaved 2 of 5, Code 39, Code 128, Code 93

## Image

Sensor	1280 x 960 high-resolution pixel array
--------	--

## Lighting/Optics

Illumination	Integrated diffuser; bright- and dark-field LED's
Reading direction	Omni-directional, pitch and skew (off-axis) angles up to 34 degrees
Aiming	Horizontal green light bar aimed at center of field of view

## I/O

Trigger	Via trigger switch in the handle
Additional outputs	Multifunctional LED and beeper to indicate good read, device status, or errors

## Communications

Interfaces	
<b>Model 7500</b>	USB and/or RS-232 for data communication, set-up, and image preview. PS2 keyboard wedge, PS2 or USB keyboard emulation
<b>Model 7550</b>	Reader to base station: Bluetooth class 2 (10m range) Base station to PC: USB/RS-232/PS2

## Power

Electrical requirements	
<b>Model 7500</b>	5VDC, 5 watts
<b>Model 7550</b>	9VDC, 18 watts
Battery	
<b>Model 7550</b>	Eight hours normal use fully charged at 25°C (77°F)

## Mechanical

Dimensions	175mm (6.9in) H 134mm (5.3in) W 81mm (3.3in) D
Material	Polycarbonate housing with shock-absorbing rubber overmold
Weight	
<b>Model 7500</b>	270g (.60lb)
<b>Model 7550</b>	Reader (with battery): 330g (.73lb) Base: 250g (.55lb)

## Environmental

Operating temperature	
<b>Model 7500</b>	-10°C to +50°C (14°F to +122°F)
<b>Model 7550</b>	0°C to +50°C (32°F to +122°F)
Storage temperature	
<b>Model 7500</b>	-40°C to +70°C (-40°F to +158°F)
<b>Model 7550</b>	-40°C to +60°C (-40°F to +140°F)
Charging temperature	0°C to +40°C (32°F to +104°F)
Operating humidity	0% – 95%, non-condensing
Storage humidity	0% – 95% non-condensing
Drop test	
<b>Model 7500</b>	50 drops from 2 meters onto concrete
<b>Model 7550</b>	25 drops from 2 meters onto concrete

## Environmental (cont'd)

Certifications	CE, (FCC, UL, and CSA pending)
IP rating	Reader: IP52 Base station: IP41

## Optional Accessories

DataMan 7500 Stand	Facilitates presentation-mode reading applications. Also provides a convenient holder for the DataMan ID Reader.
Belt and Overhead Retractors	Allows DataMan readers to automatically retract from the reading position
Wall-Mount bracket	Provides easy storage of reader

### Free Reports

These reports provide an in-depth look at the most important factors to consider when implementing DPM Identification for part traceability.

- **Implementing Direct Part Mark Considerations: Marking and Reading**
- **Implementing Direct Part Mark Considerations: Verification**

For your free copies, go to [www.cognex.com](http://www.cognex.com)



The versatility of Cognex ID products extends to industrial-grade readers for fixed-mount applications, and DPM Verifiers that confirm that a mark meets an acceptable level of quality. Your Cognex sales engineer or Automation Solution Provider (ASP) can provide information on these products.

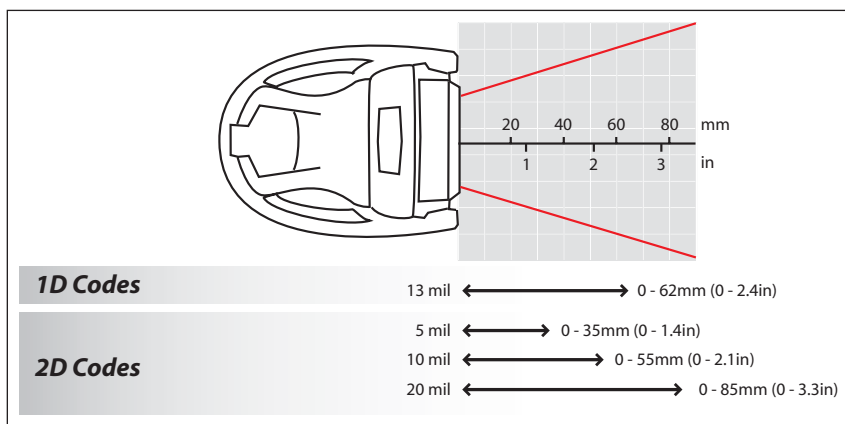

**Corporate Headquarters**  
Cognex Corporation  
One Vision Drive  
Natick  
MA 01760-2059  
USA  
Tel: (508) 650-3000  
Fax: (508) 650-3344  
[www.cognex.com](http://www.cognex.com)

## Primary Sales Offices

**United States** [www.cognex.com](http://www.cognex.com)  
(508) 652-3880

Eastern Region  
Natick, Massachusetts

Southern Region  
Nashville, Tennessee (615) 844-6158

Central Region  
Detroit, Michigan (248) 668-5100

Midwest Region  
Chicago, Illinois (630) 649-6300

Western Region  
Mountain View, California (650) 969-4812

**Europe** [www.cognex.net](http://www.cognex.net)

France +33 1 4777 1550  
Germany +49 721 6639 0  
Ireland +353 1 825 4420  
Italy +39 02 6747 1200  
Netherlands +31 402 668 565  
Sweden +46 21 14 55 88  
Switzerland +41 71 313 06 05  
United Kingdom +44 1908 206 000

**Canada** [www.cognex.com](http://www.cognex.com)  
(905) 634-2726

**Japan** [www.cognex.co.jp](http://www.cognex.co.jp)  
+81 3 5977 5400

**Southeast Asia** [www.cognex.net](http://www.cognex.net)

China +86 21 6407 5835  
Korea +82 2 539 9047  
Singapore +65 6325 5700  
Taiwan +886 3 578 0060